

Brunette Drum Chipper

Drop Feed Model



built to last



**BRUNETTE
DRUM CHIPPER**

Brunette Drum Chipper produce quality

Produces **excellent pulp chips** from short material that is difficult to control

Features **adjustable chip length** to provide operators with the flexibility to choose their desired chip length

Allows **quick knife changes** that can be done by one person

Uses single piece tapered knives that process material across their full width, providing **even wear and longer life**

Accommodates large pieces through its wide throat

A manual rotor lock prevents movement while changing knives.

Hood opening and rotor lock provide a safe working environment, while changing knives. Electrical interlocks stop the chipper if the anvil releases.

The Brunette Drum Chipper is an industry leader in producing quality pulp chips from short material.

Trim blocks

Lily pads

Log ends

Overs

Cores

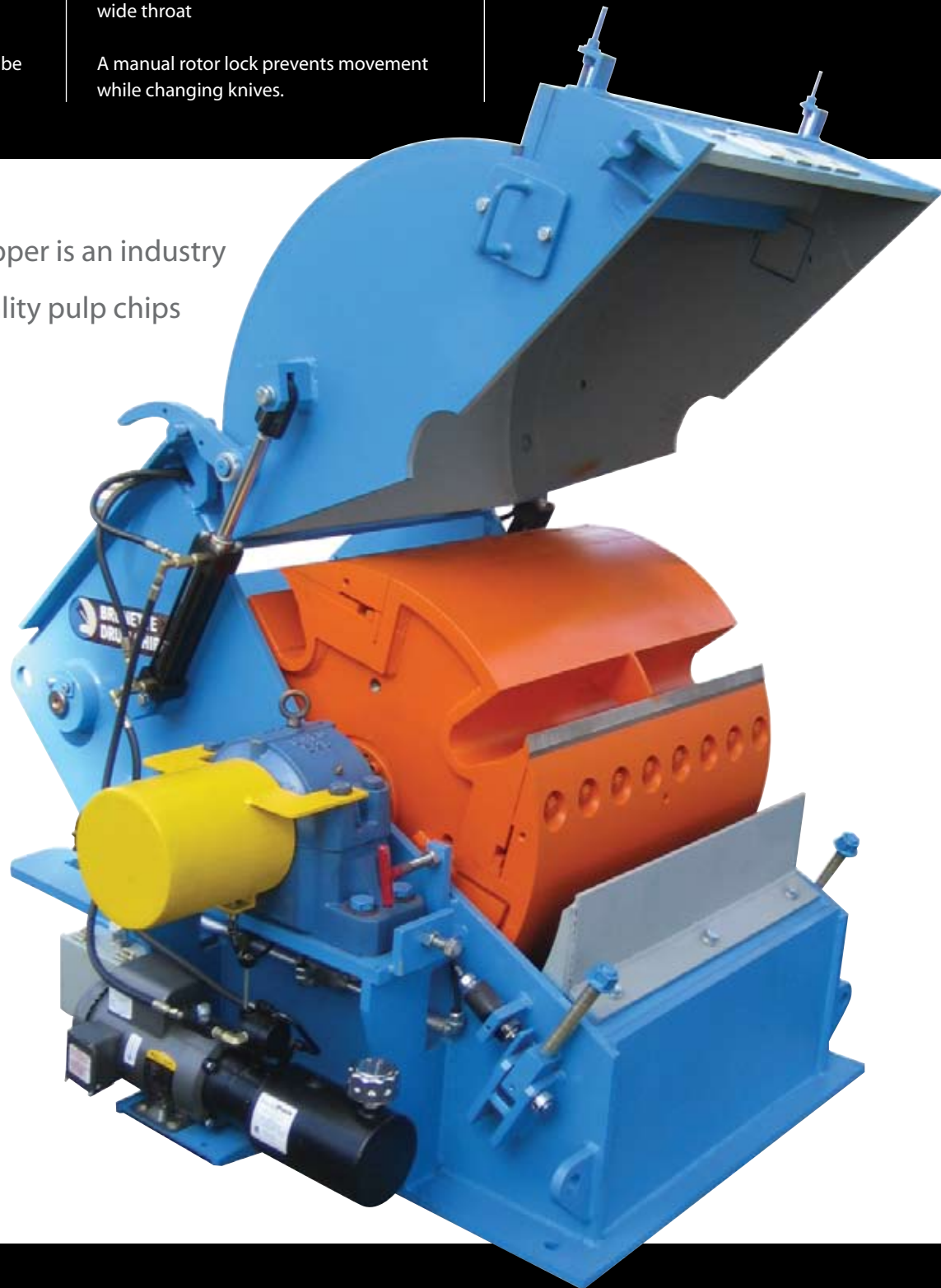

High quality pulp chips from short material

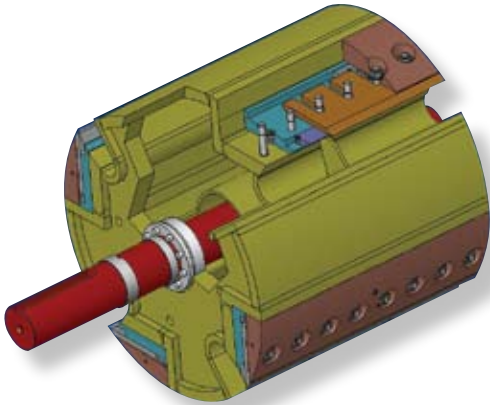

Heavy steel fabrication results in a high inertia rotor that processes high volumes and uses less energy. The rotor is mounted onto a 5"Ø HTSR shaft by taper locks.

Features quick release knife clamps (spring loaded) and replaceable counter knives.



Fabricated Screen is designed to limit the number of overs.

Pillow Block Bearings provide solid support for the rotor assembly. Hydraulic Cylinders are provided to open the large access hood for maintenance and knife changes.

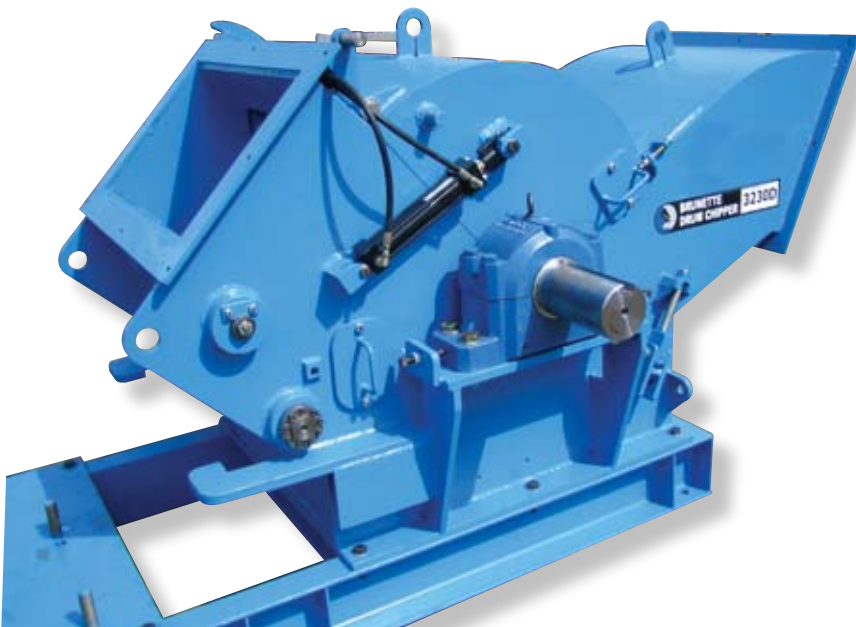

The anvil is designed to "swing-away" in the event of metal contamination. It is held in place by two shear pins mounted in taper locks.



The chipping knives are tapered and sandblasted for added safety.

The hardened anvil is reversible.

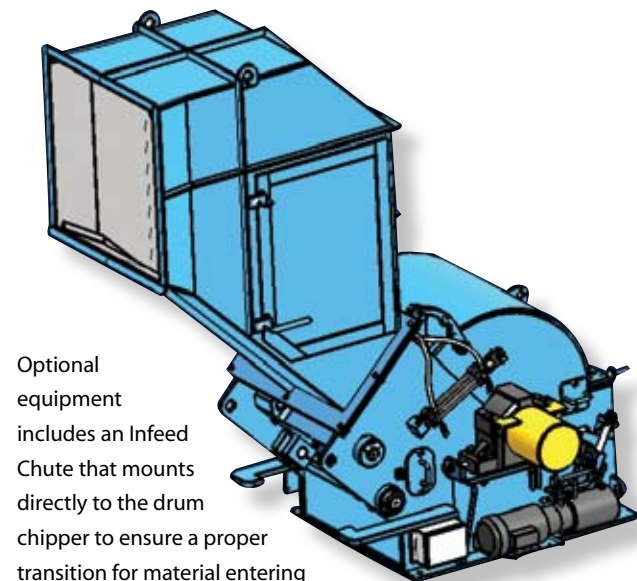

Optional equipment includes an Infeed Chute that mounts directly to the drum chipper to ensure a proper transition for material entering the drum from either a vibrating or belt conveyor.

Technical Specifications



Model	3220	3230	4830	6040
Maximum Horsepower	200	200	500	1000
No. of Knives	4	4	6	8
Drum RPM	720	720	540	360
Chips per Hour (m3) – SPF	85	125	200	425
Chips per Hour (units) – SPF	15	22	37	75
Green Tons per Hour (SWE) – SYP	37	55	92	185
Inlet Opening	16"x20"	16"x30"	22"x30"	28"x40"
Weight (Lbs.)	6200	7800	14000	20000

The Brunette Drum Chipper is available in three rotor diameters: 32", 48" and 60". Also available in rear discharge for applications with elevation restrictions.

Specifications should only be used as a general guide.
Horsepower and capacity figures will vary depending on the type of material processed.

built to last



www.brunetteindustries.com

Brunette Industries Ltd.

330 Edworthy Way
New Westminster, BC
Canada V3L 5G5

Phone: 604-522-3977
Fax: 604-522-6806
Email: sales@brunetteindustries.com

Brunette Industries Inc.

115 Brunet Way
Ball Ground, GA
USA 30107

Phone: 770-345-1400
Fax: 770-345-6191
Email: vkbi@brunetteindustries.com

BDR Machinery Ltd.

4580 Eastgate Parkway
Mississauga, ON
Canada L4W 4K4

Phone: 905-625-9236
Fax: 905-625-6437
Email: sales@bdrmachinery.com